

LIMAX1M

Magnetic Pseudo Absolute Shaft Information System

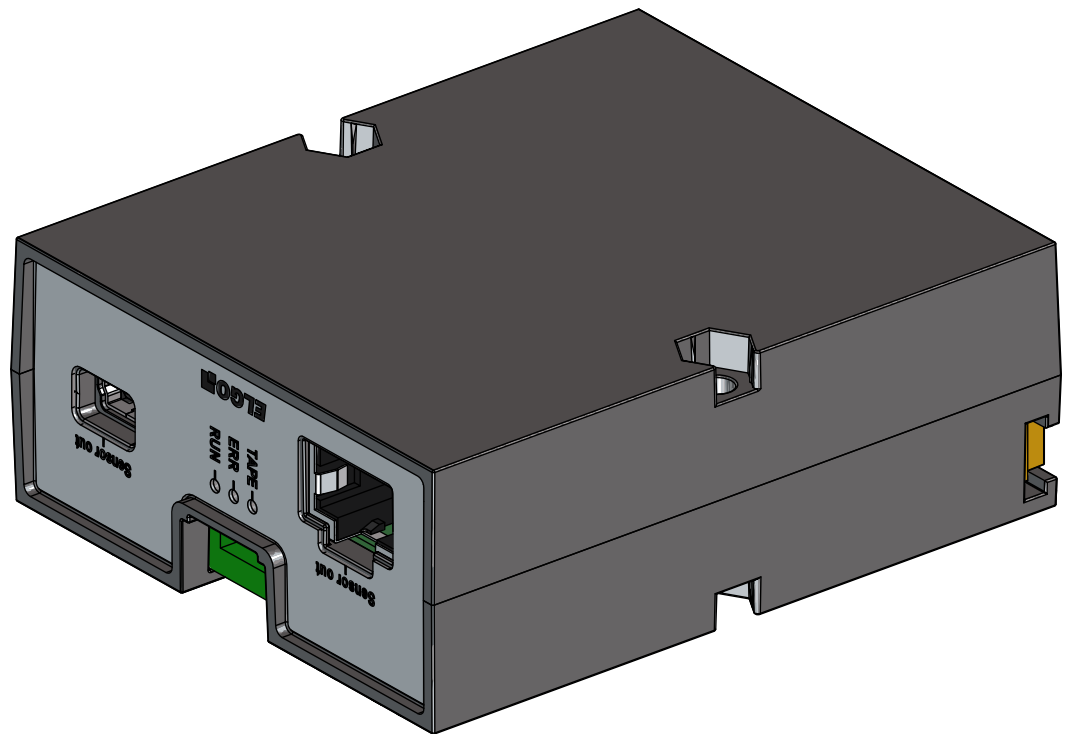

- Absolute measurement for hoisting heights up to 90 m
- Auto-referencing: Absolute position is detected after 240 mm
- Resolutions: 62.5 / 125 / 250 / 500 or 1000 μm
- Insensitive to dirt, smoke and humidity
- Travel speed up to 4 m/s (more on request)
- Interfaces: Selectively CANopen DS417, CANopen DS406, RS485, RS422, USB or SSI (on request)
- Easy and flexible to install
- Vertical installation of the magnetic tape
- Wear-free, contactless and noiseless measuring principle

LIMAX1M - Magnetic Pseudo Absolute Shaft Information System

General:

The absolute shaft information system LIMAX1M with its significant advantages is a particularly affordable, non-sensitive and easy-to-install alternative to conventional shaft information systems. During commissioning, a one-time referencing is required, which must be requested by the lift control. Then LIMAX1M always references the absolute position automatically after a moving distance of 240 mm. Compared to other shaft information systems, LIMAX1M is characterized by an extraordinarily low price.

LIMAX1M is able to cover lifting heights up to 90 meters and operating speeds up to 4 m/s.

The indication 1M in the type designation stands for "Mini" and means the smallest sensor design of the LIMAX1 series. With its low space requirement, LIMAX1M is also ideally suited for retrofitting and modernization of existing elevator systems.

A simple and flexible mounting ensures quick installation or replacement of the measuring system.

Magnetic Tape:

For measurement resp. scanning of the lift position, the LIMAX1M sensor requires an absolute coded magnetic tape of the type AB20-80-10-1-R-D-15-BK80, which carries the unique position information as a magnetic code.

The magnetic tape is mounted free-hanging in the shaft by using an ELGO mounting set (see accessories on the last page). At the lower end, the tape is tensioned while it is guided along the cabin by a plastic guidance at the sensor. The actual measurement resp. scanning is basically contactless. The guidance merely serves to keep the correct distance to the sensor.

Resolution:

Depending on the requirements, an appropriate system resolution can be defined with the order (see type designation). The available standard resolutions are 62.5 / 125 / 250 / 500 and 1000 μm .

Available Interfaces:

For communication with the lift control, an interface can be defined with the order (see type designation). Available are CANopen interfaces with different protocols as well as RS458 and RS422. Further, a USB interface with standard protocol is available. SSI interfaces (binary or Gray code) or customer-specific solutions are also available on request.

Status LEDs:

The LIMAX1M sensor has 3 status LEDs which serve for various messages, e. g. operational readiness or error states of the system, magnetic tape and interface.

Connections:

By default the LIMAX1M sensor is supplied with a RJ45 socket. To connect the sensor, a commercially available network cable can be used. In case of an ordered USB interface a Mini USB socket is equipped and a USB-cable must be used.

Sensor Installation:

In order to mount the sensor to the lift cabin, the mounting angle kit LIMAX1M MW SET (see figure right) must be used, which is available as an ELGO accessory. This mounting kit includes two screws with sliding nuts which can be inserted into the mounting groove of the sensor housing in order to fix the angle to the sensor housing. With the remaining long holes, the unit can be fastened on the cabin roof. The tape guidance at the sensor permanently ensures the correct distance between magnetic tape and sensor.

Magnetic Tape Installation:

For elevator applications, the magnetic tape is attached free hanging to the upper end of the shaft and is tensioned at the lower end of the shaft by using a tension spring. Several mounting sets are available for the tape installation, which contain different components depending on the respective requirements.

All variants and their order designations are summarized in the table "Accessories" on the last page. Available are various mounting sets as well for central guided cabins as for rucksack-guided systems (see "Accessories" on the last page).

Pin Assignment RJ45:

Pin	Function
1	VCC
2	VCC
3	CLK-
4	GND
5	GND
6	CLK+
7	CAN-H / DATA-
8	CAN-L / DATA+

LIMAX1M - Magnetic Pseudo Absolute Shaft Information System

Technical Data:

Mechanical Data

Measuring principle	Pseudo absolute
Repeat accuracy	± 1 increment
System accuracy in μm at 20 °C	± (1000 + 50 x L) L = measuring length in meters
Distance sensor / tape	the correct distance is guaranteed by guidance
Housing material	plastic
Housing dimensions	L x W x H = 82 x 68 x 30 mm
Required magnetic tape	AB20-80-10-1-R-D-15-BK80
Basic pole pitch (tape)	8 mm
Max. measuring length	90 m (240 mm relative position after power-on before absolute position is available)
Connections	standard RJ45 socket or Mini USB socket
Sensor cable	external network cable resp. USB cable required
Weight	approx. 60 g without cable

Electrical Data

Power supply voltage	10 ... 30 VDC resp. 5 VDC with USB
Residual ripple	< 200 mVpp
Current consumption	max. 100 mA
Interface	standard: CANopen DS417 optional: CANopen DS406 or USB with standard protocol on request: SSI, RS485, RS422
Available resolutions	1.0 / 0.5 / 0.25 / 0.125 / 0.0625 mm
Operating speed	max. 4 m/s (more on request)
Cycle time	250 μs

Environmental Conditions

Storage temperature	-25 ... +85 °C
Operating temperature	-10 ... +70 °C (-25 ... +85 °C on request)
Operating altitude	max. 2000 m above sea level
Humidity	95 %, non-condensing
Protection class	IP43 (standard)

LIMAX1M MW SET:

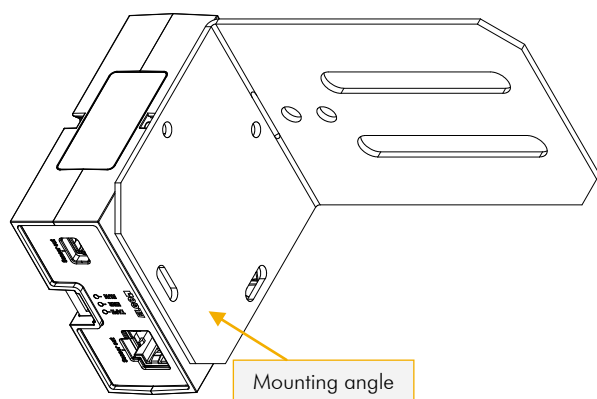

Type Designation:

LIMAX1M - - - - -

A A - B B B - C C C C - D D D D - E E E E

A Version

- 00 = standard version
- 01 = first special version (etc.)

B Signal Cable Length

- CON = connector on device (no cable)

C Resolution

- 62N5 = 62.5 μm (0.0625 mm)
- 0125 = 125 μm (0.125 mm)
- 0250 = 250 μm (0.25 mm)
- 0500 = 500 μm (0.5 mm)
- 1000 = 1000 μm (1 mm)

D Interface

- CO0T* = CANopen [encoder profile DS406]
- CO1T* = CANopen [elevator profile DS417 on request]
- USB0 = USB [standard protocol]
- 4220 = RS422 [standard protocol RS422 / position]
- 4850 = RS485 [standard protocol RS485]
- SSB0 = SSI [25 bit binary code / position] on request
- SSG0 = SSI [25 bit Gray code / position] on request

E Connection Options

- RJ45 = RJ45 socket
- USBM = Mini USB socket

*) **REMARK:** The CAN interface is generally terminated by 120 R (T),
but not galvanically separated

Order example:

LIMAX1M - 0 0 - CON - 1 000 - USB 0 - USBM
A A - B B B - C C C C - D D D D - E E E E

ELGO standard LIMAX1M with 1 mm resolution, USB interface and
micro USB socket

Bottom view:

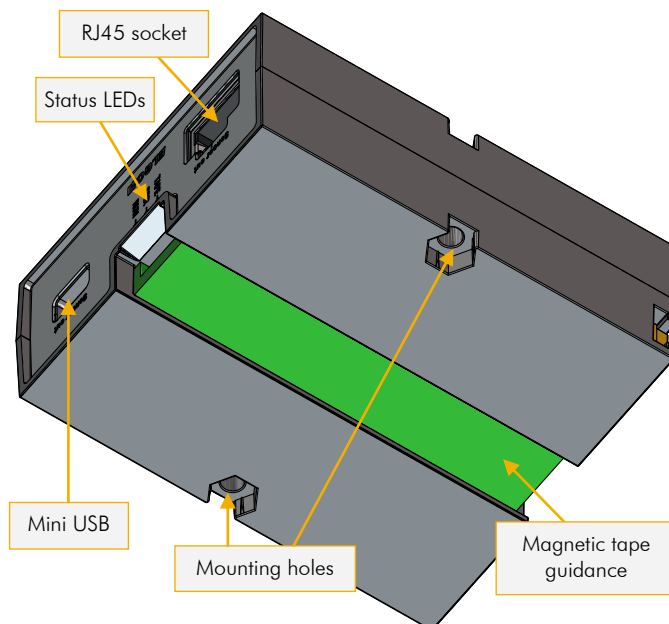

Dimensions of LIMAX1M:

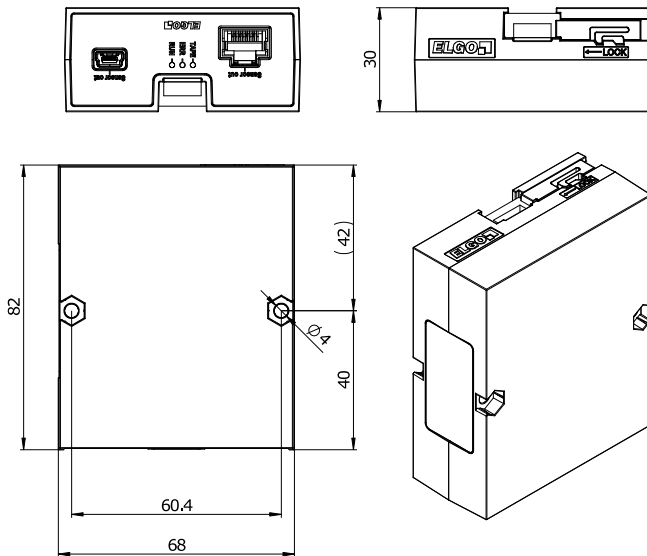

Dimensions with Mounting Angle:

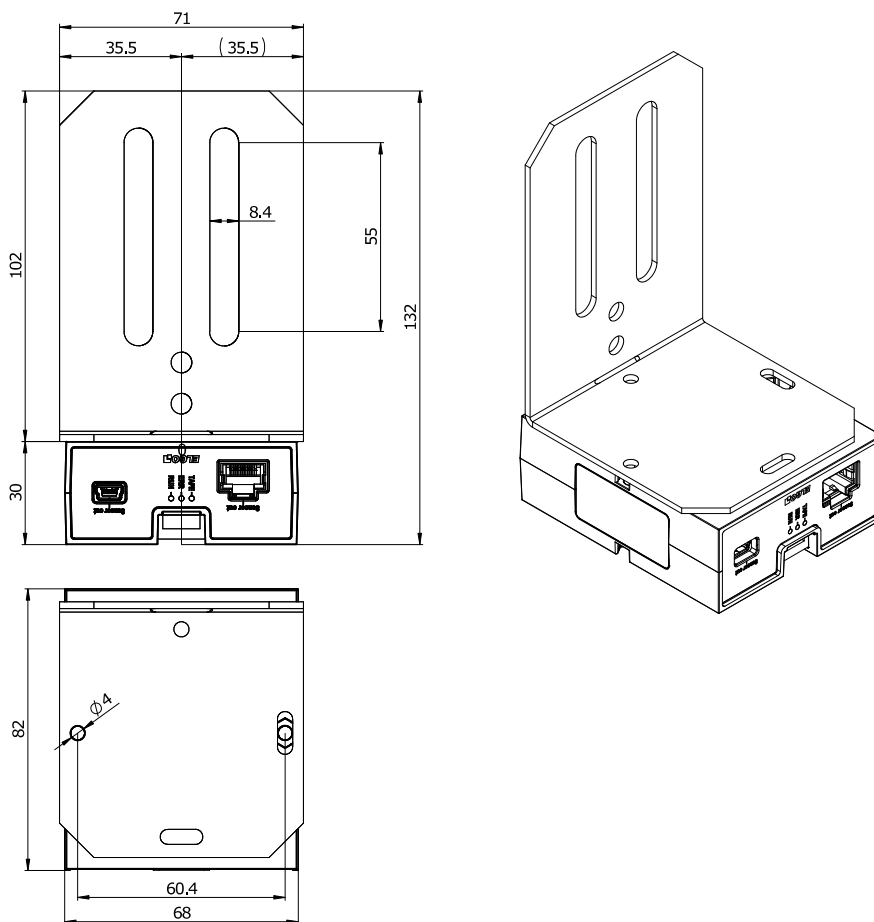

Accessories for LIMAX1M:

Order designation	Description
LIMAX1M MW SET	LIMAX1M mounting angle for attachment to the lift cabin
AB20-80-10-1-R-D-15-BK80	Magnetic tape for LIMAX1M, absolute coding, single track system
LIMAX MKF	Mounting set for suspended installation with dowel
LIMAX MKB	Mounting set for suspended installation with guiding rails and rail holder
LIMAX RMS	Mounting set for suspended installation with crossbeam for standard layout
LIMAX RMS 90	Mounting set for suspended installation with crossbeam for Rucksack-layout

