

AZK03

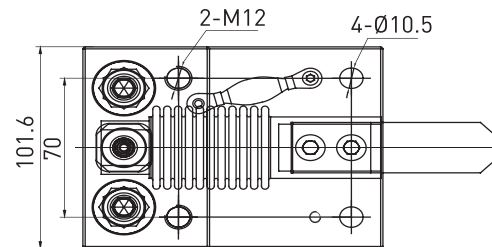

Size and Capacity

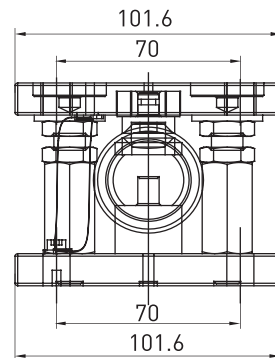
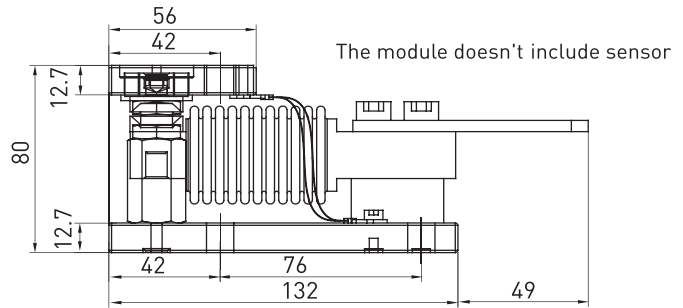

Features & Applications

- Made of stainless steel
- Suitable for sensor F3833
- Mainly used for hopper scales, packing scales, feeder and industrial weighing systems

Load Direction

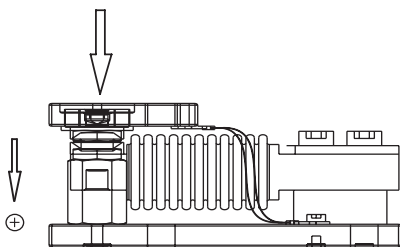

Schematic Wiring Diagram

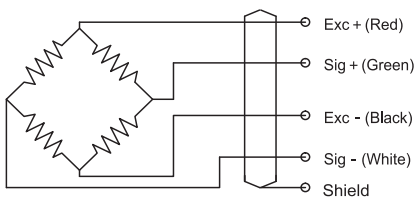

Note: Cable shield is not connected to element.

Mounting

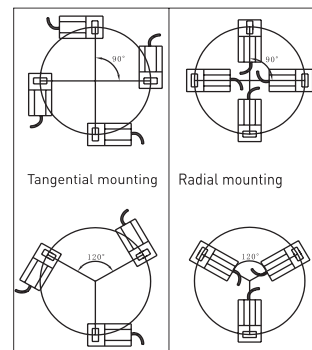
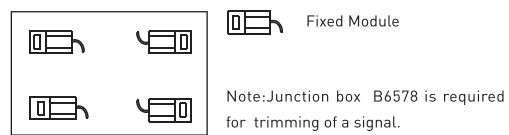

Capacity (kg)	Material	Weight
5/10/20/30/40/50/75/100 150/200/250/300/500	Stainless Steel	2.4kg